

ASNT5131/5030-PQC 17Gbps Limiting Amplifier

- Broadband (DC-17Gbps) limiting amplifier featuring output signal amplitude adjustment from 0.0V to 1.0V single ended.
- Exhibits low jitter and limited temperature variation over industrial temperature range.
- 100MHz of bandwidth for the amplitude adjustment tuning port.
- Ideal for high speed proof-of-concept prototyping.
- Fully differential input and output buffers with on-chip 50Ω termination.
- CML output interface with nominal 500mV single-ended swing.
- Single -5.0V power supply.
- Power consumption: 500mW.
- Fabricated in SiGe for high performance, yield, and reliability.
- Standard MLF/QFN 24-pin package.

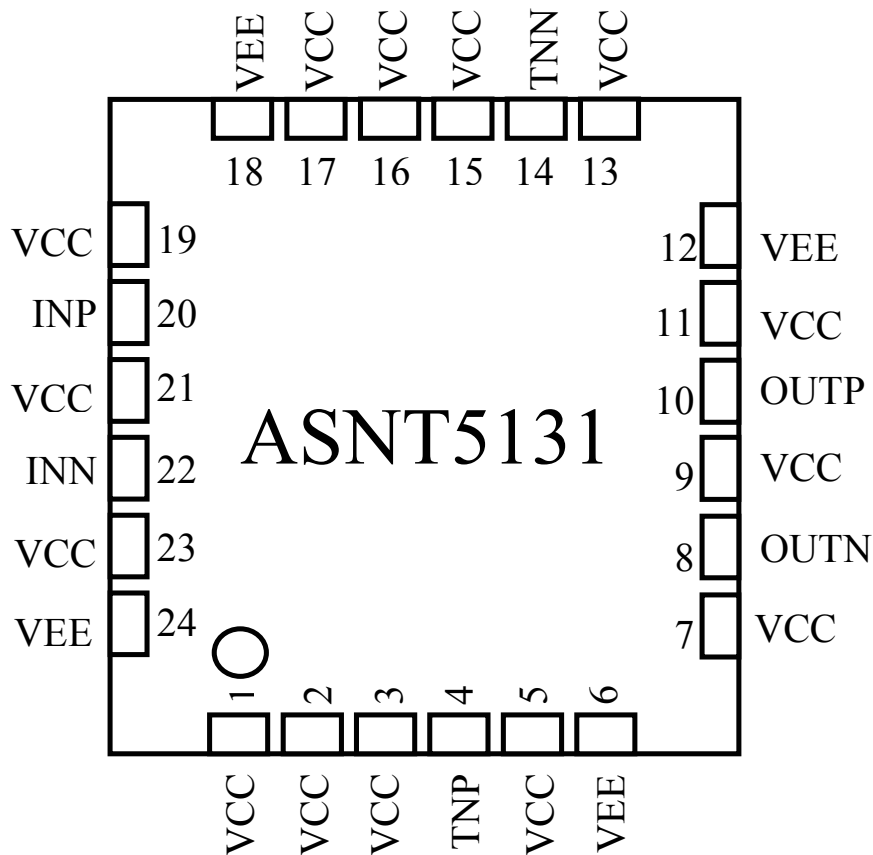

DESCRIPTION

The temperature stable ASNT5131-PQC SiGe IC provides extremely low jitter broadband signal amplitude control capability between its input and output signal ports and is intended for use in high-speed measurement / test equipment. ASNT5131-PQC can process an up to 17Gbps data signal and deliver output signal amplitudes between 0.0V-1.0V through the up to 100MHz external adjustment of its differential tuning port. The part's I/Os support the CML logic interface with on chip 50Ω termination and may be used differentially, AC/DC coupled, single-ended, or in any combination. It operates from a single -5.0V power supply.

FUNCTIONAL BLOCK DIAGRAM

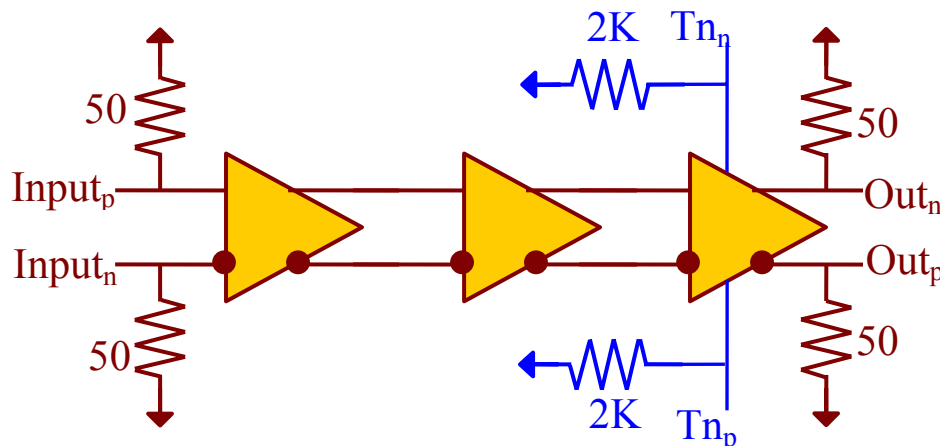

TERMINAL FUNCTIONS

TERMINAL NAME (NO.)	TYPE	DESCRIPTION
vcc 1-3,5,7,9,11 13,15-17,19,21,23	PS	Power Supply: 0V
vee 6,12,18,24	PS	Power Supply: -5.0V
inp 20 inn 22	Input	Differential CML high-speed data signal inputs
outp 10 outn 8	Output	Differential CML high-speed data signal outputs
tnp 4 tnn 14	Input	Differential low-speed amplitude adjustment tuning inputs



ELECTRICAL CHARACTERISTICS

PARAMETER	MIN	TYP	MAX	UNIT	COMMENTS
VEE	-4.75	-5.0	-5.25	V	±5%
VCC		0.0		V	
IEE		100		mA	
Power		500		mW	
Junction Temp.	-25	50	125	°C	
Input (in)					
Frequency	0.0		17	Gbps	
CM Level	V _{cc} -0.8	V _{cc} -0.2	V _{cc}	V	
Swing (Diff or SE)	50	400	1000	mV	Peak-to-peak
Output (out)					
Frequency	0.0		17	Gbps	
CM Level*	V _{cc} -0.3	V _{cc} -0.25	V _{cc} -0.2	V	
SE Swing*	475	500	525	mV	Peak-to-peak
Rise/Fall Times	15	17	19	ps	20%-80%
Additive Jitter			<1	ps	Peak-to-peakv
Duty Cycle	45%	50%	55%		
Tuning Port (tn)					
Diff. Swing	-500		500	mV	Peak-to-peak
CM Level	V _{cc} -0.5	V _{cc} -0.25	V _{cc}	V	
Amplitude Variation	0.0	500	1000	mV	
CM Level	V _{cc} -0.5	V _{cc} -0.25	V _{cc}	V	
Bandwidth	0.0		100	MHz	
* Tuning Pins are N/C					

PACKAGE INFORMATION

The chip is packaged in a standard 24-pin QFN package. The package's mechanical information is available on the company's [website](#).